



BMW K 1200 S (2005)

Slip-On Exhaust System

# Akrapovic Open Slip-On Exhaust System for the BMW K 1200 S (2005)

The most recent addition to the famous German line is known for its sporty elegance and technical refinement. To give it an extra performance boost with a small investment we have developed the Akrapovic SLIP-ON exhaust system. The system allows the K's engine to breathe more freely, resulting in improved performance characteristics.

## PERFORMANCE

Measurements of the Akrapovic SLIP-ON system on the BMW K 1200 S (without noise damper):

Power & Torque: despite the excellent performance of the stock machine, the Akrapovic SLIP-ON manages to add both power and torque. The increase in power can be seen in the low end between 2000 and 3000 rpm, and then from 5400 rpm right to the top of the range, where the engine responds the most to the new exhaust. Max. power of 159.2 HP is measured at 10230 rpm, and max. increased power of 7.2 HP is shown at 7760 rpm. The torque curve for the Akrapovic SLIP-ON shows a similar response.

## CONFIGURATION

The Akrapovic SLIP-ON system is composed of a cylindrical stainless steel link pipe attached to the muffler with a sleeve joint held together with silicon-shielded tensioning springs. At the other end the Akrapovic link pipe is attached to the stock header assembly with another sleeve joint, this time held together with the stock metal clamp. The muffler is available with either a titanium or carbon-fiber outer sleeve. The difference is purely visual, as the performance for both models is the same. The muffler interior (inlet and outlet cap, inner perforation) is made entirely of titanium, making it much lighter than the stock muffler, and the muffler is attached to the frame using an Akrapovic carbon-fiber clamp.

## OPTIONS

The muffler outer sleeve is available in either titanium or carbon-fiber.

	PERFORMANCE		
	stock	AKRAPOVIC	max. increased power
max. rear wheel power HP / rpm <small>(measured on SuperFlow Cycle Dyn)</small>	155.2 / 10210	159.2 / 10230	7.2 / 7760

	CONFIGURATION		
	header tubes	collector	link pipe
material	-	-	STAINLESS STEEL
tube shape	-	-	CYLINDRICAL

interference crossover tubes	-	lambda sensor	-
header tube inner sleeves	-	header tube flanges	-
header tubes - collector connection	-	collector / header tube - link pipe connection	SLEEVE JOINT + STOCK METAL CLAMP
link pipe - muffler connection	SLEEVE JOINT + SILICON SHIELDED SPRINGS	muffler inlet cap / outlet cap	TITANIUM / TITANIUM
muffler metal interior	TITANIUM	muffler outer sleeve	TITANIUM / CARBON-FIBER
muffler clamp	CARBON-FIBER ROAD	muffler bracket	-
noise damper	-	heat shield	-

OPTIONS				
link pipe	noise damper	muffler outer sleeve	muffler bracket	heat shield
-	-	TITANIUM / CARBON-FIBER	-	-

	ADDITIONAL DATA				
	stock	AKRAPOVIC		difference	
		S.S. link pipe	TITANIUM link pipe	stock - S.S.	stock - titanium
weight comparison (kg)	7.60	2.20	-	5.40	-
noise measurements (dB / rpm)	stock		AKRAPOVIC		
	95.4 / 5125		100.5 / 5125		
possibility of periodic service without removing A.E.S.	oil		oil filter		
	YES		YES		
legal for street use	NO				

Technical specifications of Akrapovic exhaust systems and related products subject to change without notice.

Product code: 104428 (S-B12S01-C)  
104427 (S-B12S01-T)



# Akrapovic Open Slip-On Exhaust System for the BMW K 1200 S (2005)



CARBON-FIBER  
MUFFLER CLAMP

Product code: 104428 (S-B12SO1-C)  
104427 (S-B12SO1-T)

# Akrapovic Open Slip-On Exhaust System for the BMW K 1200 S (2005)



Akrapovic Exhaust System Technology copyright 2005, all rights reserved

Road  
Program

Product code: 104428 (S-B12SO1-C)  
104427 (S-B12SO1-T)

# Akrapovic Open Slip-On Exhaust System for the BMW K 1200 S (2005)



Akrapovic Exhaust System Technology copyright 2005, all rights reserved

Road  
Program

Product code: 104428 (S-B12SO1-C)  
104427 (S-B12SO1-T)

# Akrapovic Open Slip-On Exhaust System for the BMW K 1200 S (2005)

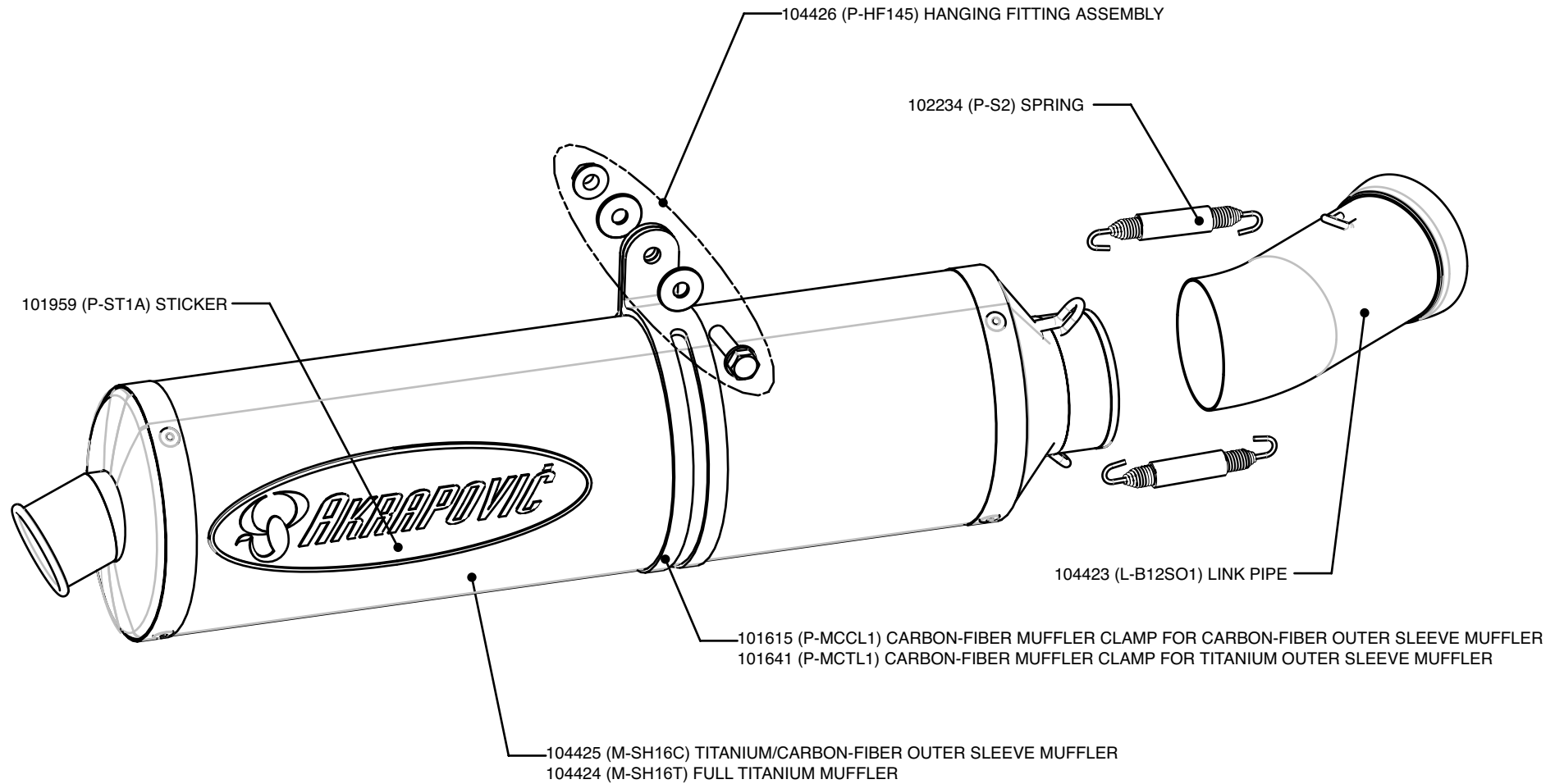

Road  
Program

Product code: 104428 (S-B12SO1-C)  
104427 (S-B12SO1-T)

# Akrapovic Open Slip-On Exhaust System

for the BMW K 1200 S (2005)

 STOCK EXHAUST

 AKRAPOVIC SLIP-ON EXHAUST  
(without noise damper)

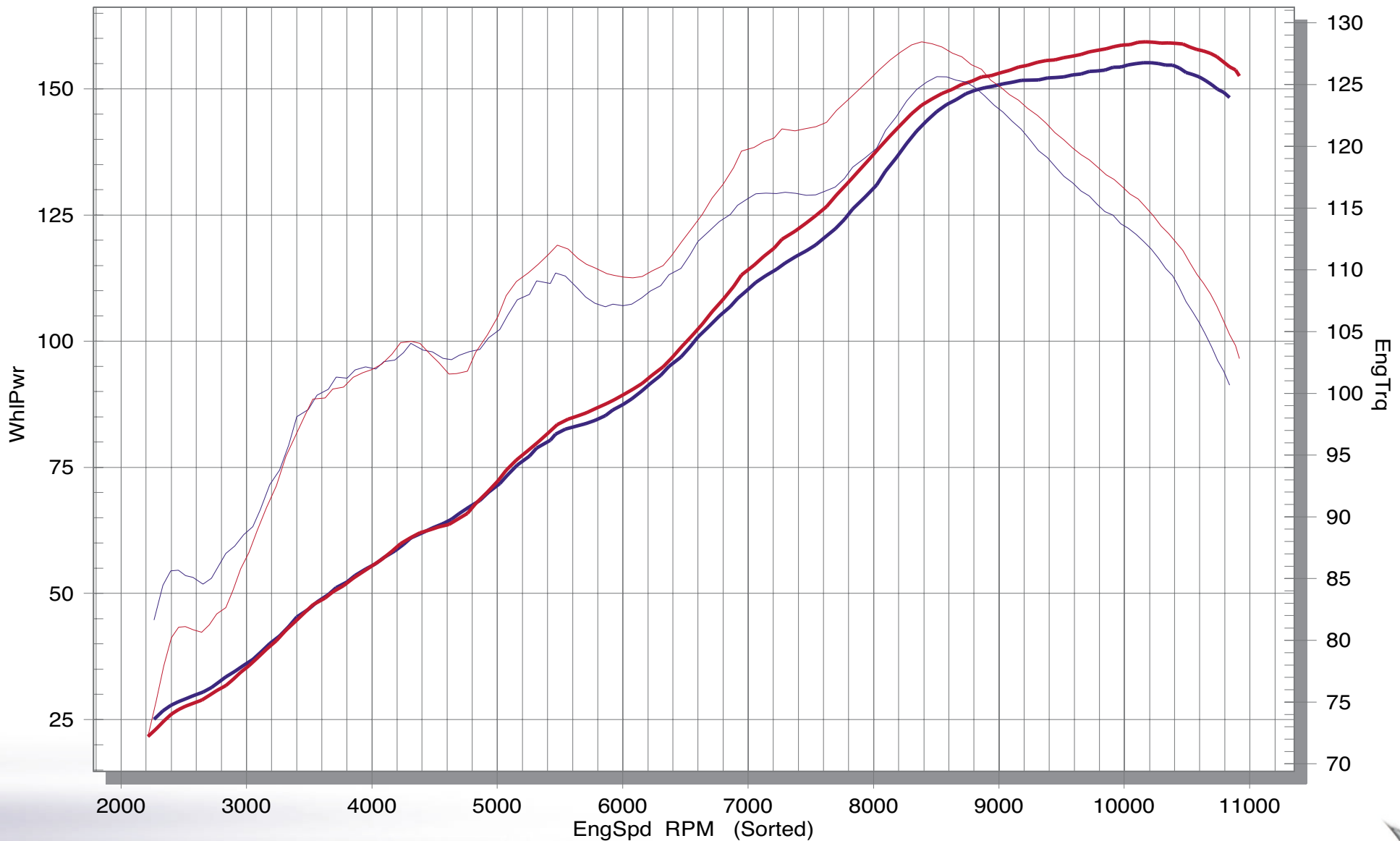

Road Program

Product code: 104428 (S-B12SO1-C)  
104427 (S-B12SO1-T)